

Silent-Cleaner SC60-50S W/F

Instructions

① Please make sure the following parts are contained inside the package:

Silent-Cleaner	1
60L Stainless Steel (SUS) Tank on Carriage	1
Front wheel: 1, Rear wheel: 2, Washer: 4, R Pin: 2, Caster Shaft: 2, Spanner/ wrench	
Suction Pipe	1
Hose	1
Hose Clamp	2
Spare Filter (for fine dust collection)	1

② To attach the casters, please refer to the last page of this manual.

③ Put the Silent-Cleaner on top of the 60L SUS tank and fasten with the draw latches.

④ Attach the hose with the suction mouth of the Silent-Cleaner and fasten well with the hose clamp.
(It can be made easier by turning the hose clockwise while attaching.)

⑤ Connect the suction pipe with the hose and fasten well with the hose clamp.
(It can be made easier by turning the hose clockwise while attaching.)

⑥ Connect the air hose (ID over 19mm) with the Silent-Cleaner. For optimal performance, while connecting, please make sure that the air filter is present in between the connection to prevent rust entering into the device.

Please make sure that the air valve is closed when connecting the air hose.

⑦ Suction will start as soon as the air cock is turned open on the Silent-Cleaner.

★ Peep Hole can be easily taken off for inspection.

★ When the vacuum power is low, please check for the following:

(1) Air pressure is at sufficient level, or air volume is sufficient.

(2) Connecting the appropriate air hose, not too long or too thin.

(3) Connecting with the minimum numbers of couplers, or connecting the inappropriate couplers lead to insufficient airflow and may not be able to maintain optimal performance.

★ Feature

Silent-Cleaner has the following extraordinary feature:

● The Safety valve prevents sudden vacuum level increase when the suction mouth is blocked and avoids damage to the device or the tank.

● Please do not randomly adjust the safety valve to prevent any damage or danger.

★ Caution

● When the vacuum level decreases it indicates that the filters require replacement.
Please use the air hose with 3/4" for the best performance.

Fine Dust Filter

● The fine dust is caught at the cloth cover(exterior) primarily and then at the fine dust filter inside.
Please replace the fine dust filter occasionally to prevent the filter from getting clogged, causing the excessive vacuum level at the suction area, or the fine dust flowing to the silent filter.

Silent Filter

● Please make sure to supply clean compressed air to prevent the silent filter from getting clogged with rust or oil in addition to the fine dust discharged through the fine dust filter.

Please take off the fine dust filter for the liquid suction.



TEL: +81-6-6572-1207

FAX: +81-6-6572-1256

E-mail: osawa@osawa-company.co.jp

In case you have any inquiry, please contact the dealer or the manufacturer.

How to reassemble the filters

The Fine Dust Filter is preinstalled in this device. However, when dismantling the filter for cleaning or replacement, please reassemble in the following order:

- (1) Invert the Silent-Cleaner.
- (2) Push the bolt ① (shorter side) into the cleaner body.
- (3) Put the Punching Metal (Small) ⑤ & the Fine Dust Filter and Punching Metal (Large) ④ & the Cloth Cover (White) on the cleaner body.
- (4) Fit the Filter Cover ③ with the bolt ① and fasten the Butterfly Nut ②.

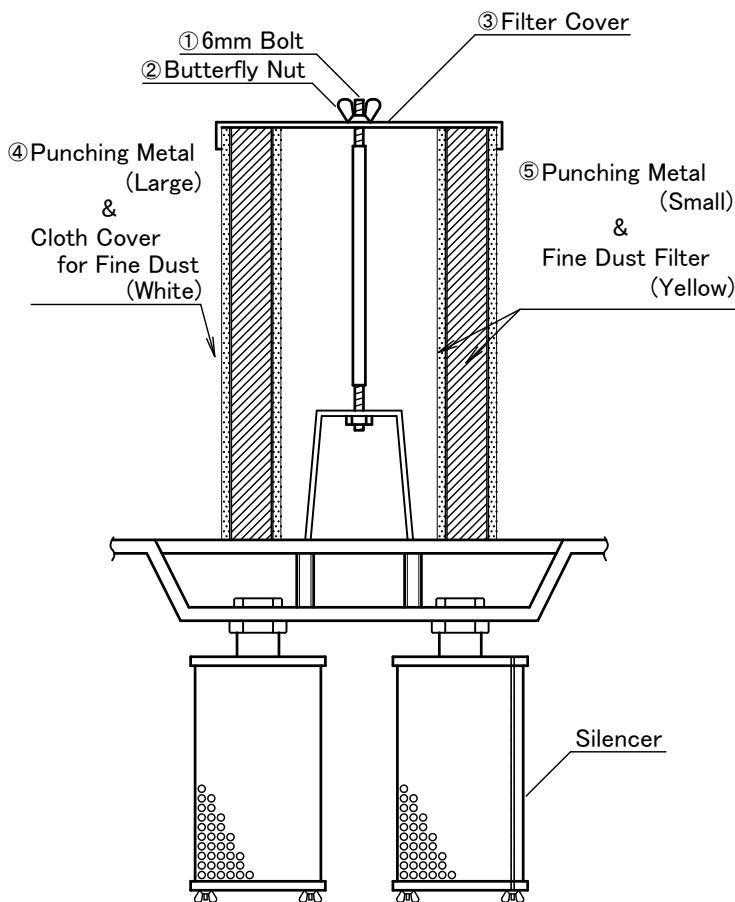

Attention:

- When the vacuum level decreases, it indicates that the Cloth Cover ④ requires cleaning. Please clean the Cloth Cover occasionally. If the vacuum level is not regained, please replace the Fine Dust Filter ⑤.
- Please replace the Fine Dust Filter occasionally to prevent the excessive vacuum level at the suction area and the dust flowing to the Silent Filter.

How to order the filters:

- To order the fine dust filter (Yellow), please specify as FINE DUST FILTER (Large) for SC60-50S W/F, available from 6pcs in 1 set.
- To order the Cloth Cover for fine dust (White), please specify as CLOTH COVER FOR FINE DUST (Large), for SC60-50S W/F, available from 2pcs in 1 set.
- Silent Filter is located inside the Silencer. Please specify as SILENT FILTER (for all Silent-Cleaner models), available from 1pc.

How to order the Hydro Stopper (Option)

- For the liquid suction, installing the Hydro Stopper will provide a good performance. The Hydro Stopper is the device to control the quantity of vacuuming liquid when the deposited liquid comes up to the preset level inside the tank, it automatically closes the suction mouth to stop the liquid suction. To order the Hydro Stopper, please specify as HYDRO STOPPER (for all Silent-Cleaner models), available from 1set.



Caution!

It is advised that the following materials are not suitable for suction or transfer, since they may cause explosion, fire, electric shock, or dust explosion resulting in serious damage to human body/ life

- Explosive dust: e.g. Aluminum, Magnesium, titanium, zinc, high conductivity dusts, etc.
- Sparks or high thermal materials from high-speed cutter, grinder or welder
- Inflammable materials: e.g. gasoline, thinner, chemicals
- Sharp material: e.g. needles, nails, etc.
- Other materials considered as dangerous to vacuum in general situation



1-7-28, Yunagi, Minato-ku, Osaka 552-0004 Japan
TEL: +81-6-6572-1207 FAX: +81-6-6572-1256
URL <https://www.osawa-company.co.jp>
E-mail: osawa@osawa-company.co.jp

SILENT CLEANER Caution!



DANGER

Please do a thorough read prior to the operation.

- Do not suck anything considered as dangerous in general situation
- Do not suck anything with the temperature over 40°C to prevent burning or fire
- Do not misuse as it may cause serious damage to human body / life
- Please use antistatic parts for controlling static electricity to prevent explosion, fire or electric shock
- Please make sure that explosive dust is controlled when vacuuming to prevent the dust explosion
If not, dust explosion might lead to serious damage to a human body / life

CAUTION

- Please check if all the parts are tightened properly prior to each operation
- Please make sure that no foreign substance is caught in the moving part, or the device may not operate properly
- Do not give any shock to the drum when the drum is at high vacuum level to prevent the crashing of the drum that might lead to the risks of explosion of the contents inside the drum
- Please do a regular inspection of the drum inside
Do not vacuum liquid close to the top of the drum to prevent the liquid from spraying out of the filter on top
For liquid suction, HYDRO STOPPER is recommended
- Do not overturn/knock over the drum to prevent the contents from emerging out
- Use with the air pressure gauge under 0.9MPa (9kg/cm²)
- Keep out of reach from children
- Please read thoroughly the instruction manual prior to operation
In case you have any question about the usage, stop operation immediately and inquire the manufacturer

It is advised that the following materials are not suitable for suction or transfer, since they may cause explosion, fire, electric shock, or dust explosion resulting in serious damage to human body/ life

- Explosive dust: e.g. Aluminums, Magnesium, titanium, zinc, high conductivity dust, etc.
- Sparks or high thermal materials from high-speed cutter, grinder or welder
- Inflammable materials: e.g. Gasoline, thinner, chemicals.
- Sharp material: e.g. Needles, nails, etc.
- Other materials considered as dangerous to vacuum in general situation

*** Please keep this caution note at a place where the operator can easily read at anytime**



1-7-28, Yunagi, Minato-ku, Osaka 552-0004 Japan
TEL:+81-6-6572-1207 FAX:+81-6-6572-1256
URL <https://www.osawa-company.co.jp>
E-mail: osawa@osawa-company.co.jp

Check when Low Performance

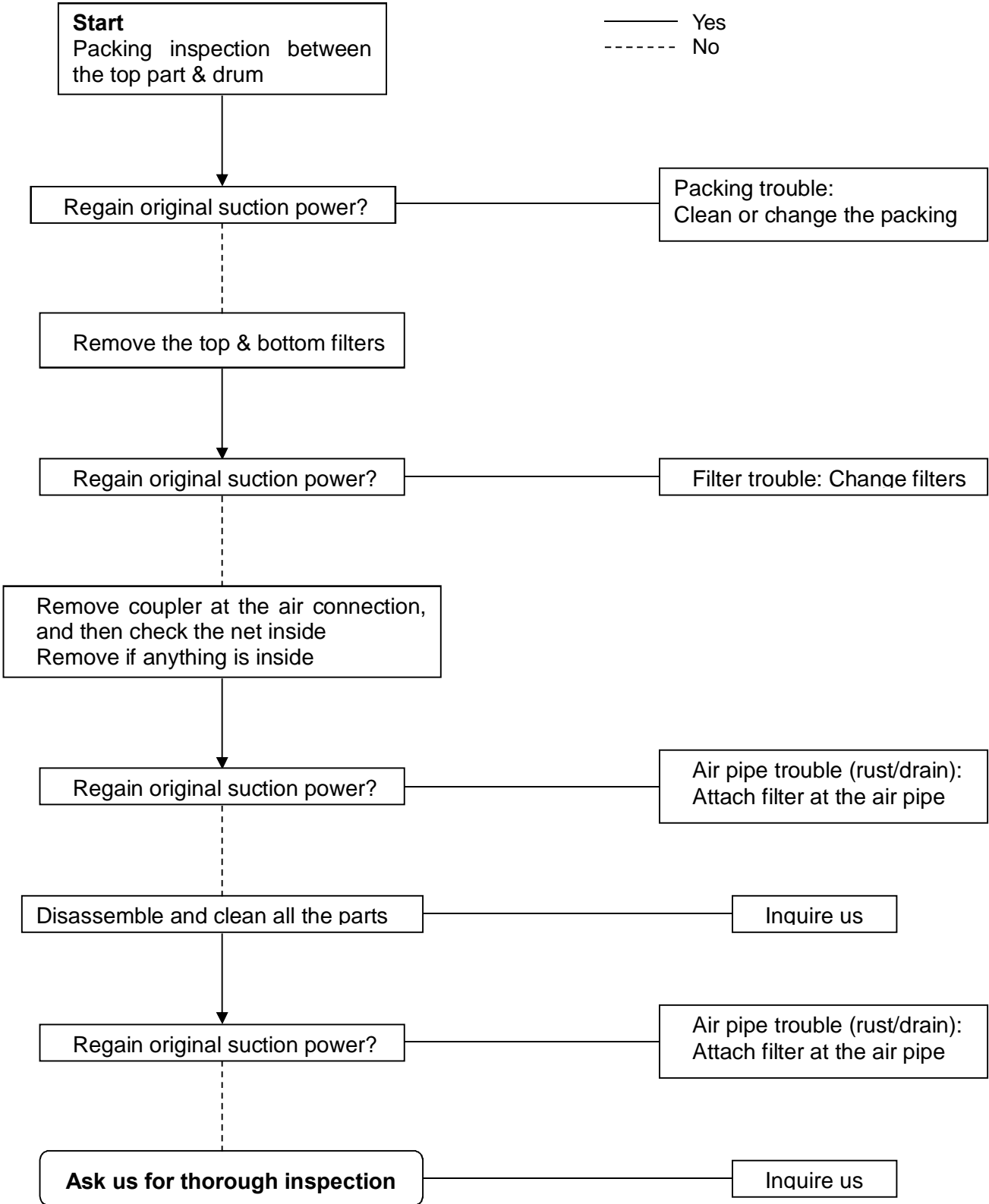

How to Attach the Casters

Caster Components	Name of each part	Qty
	① Carriage for SC60	1
	② Front Wheel for SC60 with brake	1
	③ Rear Wheels for SC60	2
	④ Flat Washers for Rear Wheels	4
	⑤ R Pins for Rear Wheels	2
	⑥ Caster Shafts for SC60	2

How to Attach the Casters

1. Fix the Caster Shafts ⑥ at the holes on the back side of Carriage ①
2. Attach the Flat Washers ④ with the rough surface facing inside with each Caster Shafts ⑥
3. Attach the Rear Wheel ③ on the Caster Shafts ⑥
4. Attach the rest of Flat Washers ④ with the rough surface facing the inside with each Caster Shafts ⑥ again
5. Fix the R Pins ⑤ to each Caster Shafts

※ Attach the Front Wheels ② by the attached spanner/ wrench (21mm) with the holes for screw on the front side of the Carriage ①

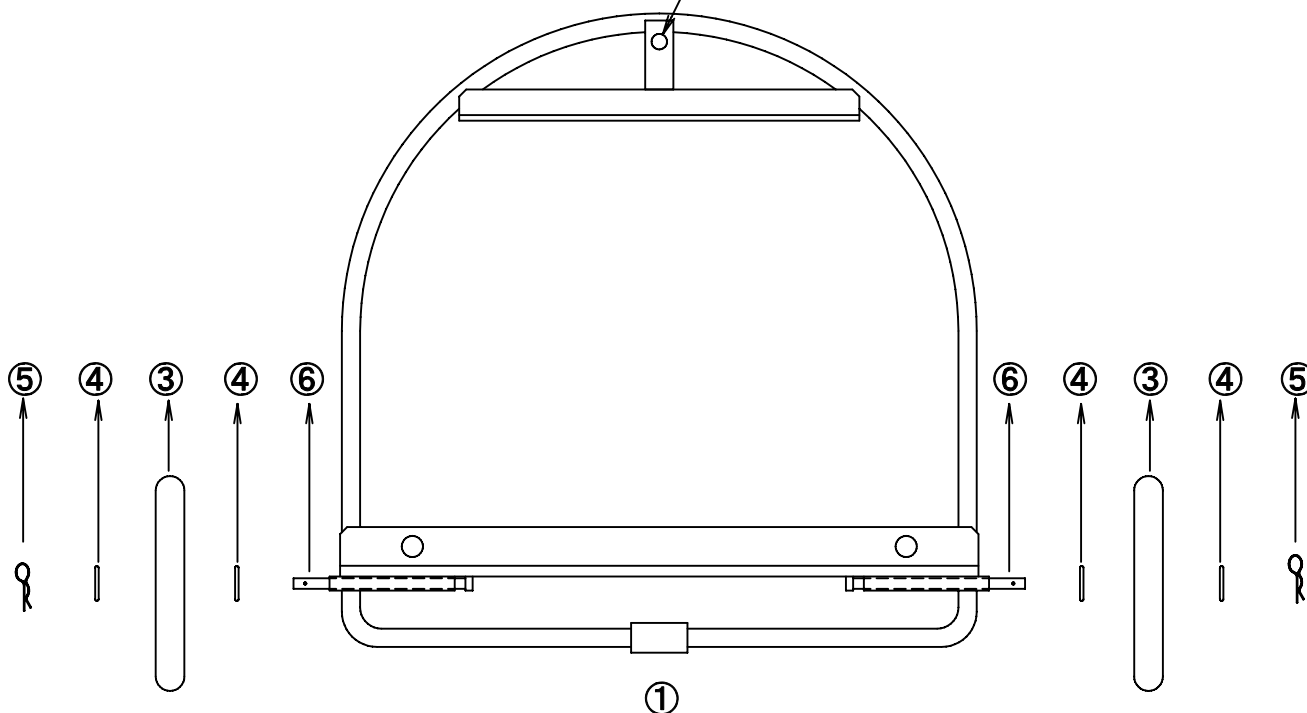

Replacement Parts are available at any time

**WONDER
GUN**



OSAWA & COMPANY

OSAWA CO. LTD.

1-7-28, Yunagi, Minato-ku, Osaka, 552-0004 Japan

TEL +81-6-6572-1207

FAX +81-6-6572-1256

e-mail osawa@osawa-company.co.jp

<https://www.osawa-company.co.jp>